



**THE RETROFIT SOURCE**  
*The Best Brands in Automotive Lighting*

[support@theretrofitsource.com](mailto:support@theretrofitsource.com)  
404.220.7940

# INSTALLATION GUIDE:

## 2008-14 IMPREZA RETROQUIK SYSTEM

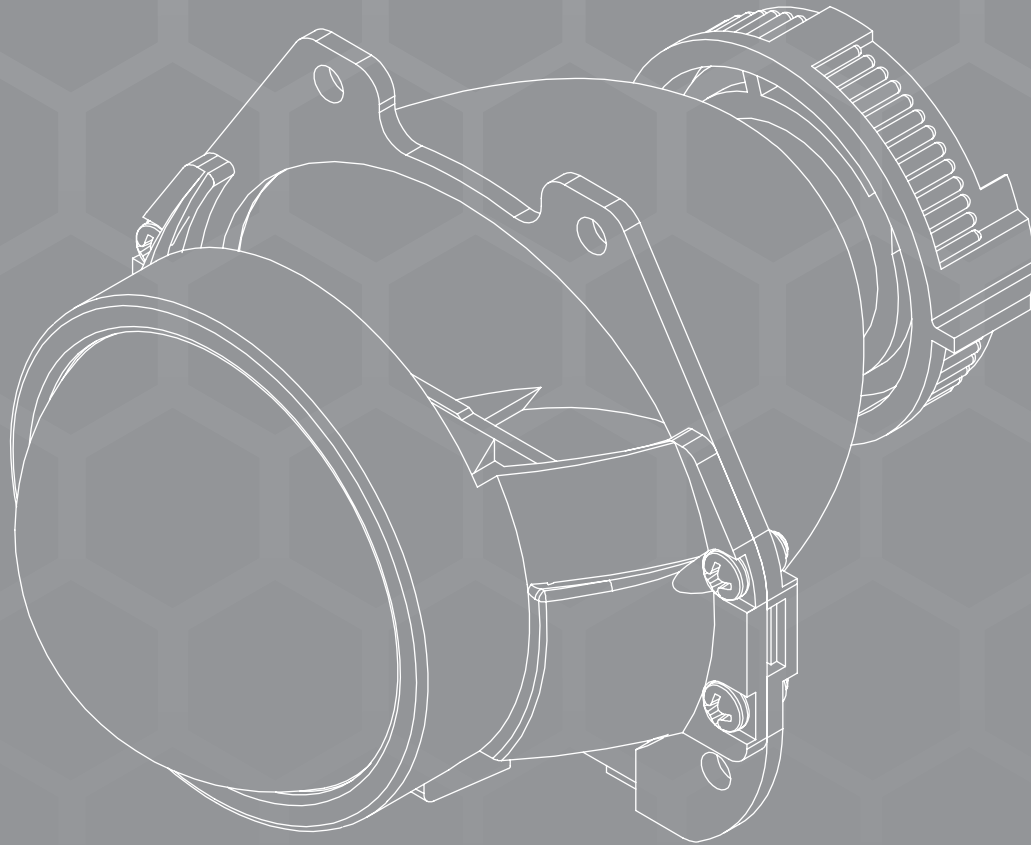



**WARNING:** By reading this document, I agree it is only to be used as an educational guide. The Retrofit Source makes no guarantee on any finished results, nor are they to be held responsible for any damage, misuse, or personal injuries. Use at your own risk. If you are unable to clearly understand and adapt the information below to your own application, professional installation is recommended.

## TABLE OF CONTENTS

System Diagram	3
Opening Headlights	4
Hardware Assembly	5
Resealing Headlights	6
Harness Installation	8
Solenoid Wiring	8
Bulb Installation	8
Ballast Installation	9

## STANDARD PARTS

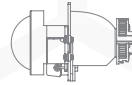

2x 4TL-R Projectors

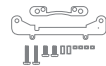

RetroQuik Hardware

## INCLUDED WITH COMPLETE KIT



1x Ballast Test Lead



2x Matsushita O-Rings

## OPTIONAL PARTS



2x D2S HID Bulbs



2x Matsushita Ballasts

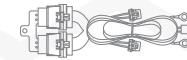

1x Wire Harness



2x High Beam Splitters



1x RetroRubber Sealant

### SPECIAL NOTE:



Ballast Test Lead

The included ballast test lead is used for troubleshooting purposes only and is not part of the installation of this system. If necessary, the test lead can be plugged into the ballast input then connected to a 12V+ source to test the ballast. This must be done with the bulb connected to the ballast prior to applying power.

# SYSTEM DIAGRAM

## Left Side of Vehicle

## Right Side of Vehicle

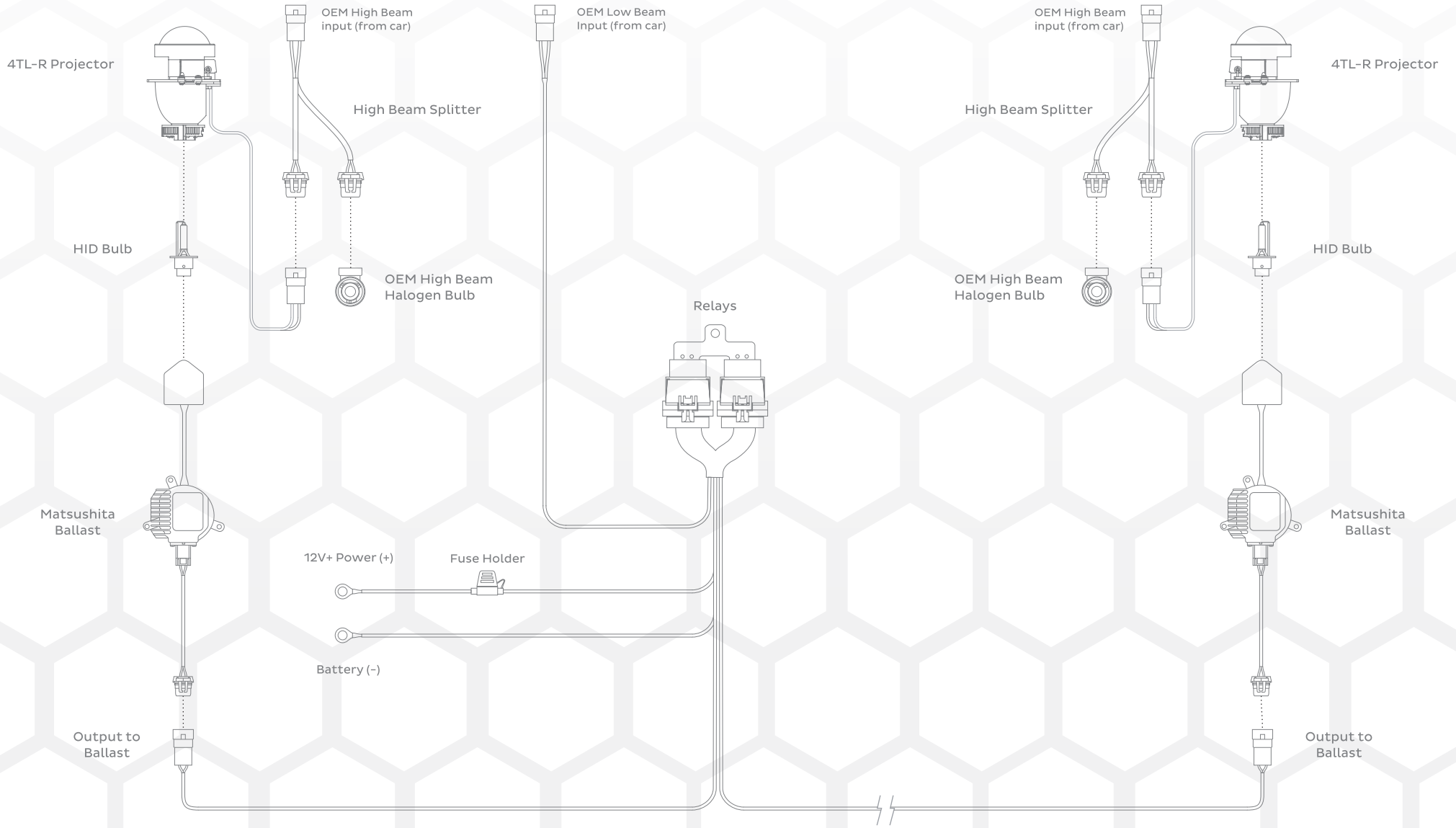

# OPENING HEADLIGHTS

---

1

Place headlight in oven for seven (7) minutes at 270 Fahrenheit / 130 Celsius to soften the existing sealant. Be sure no wires or other hanging parts are touching the wire rack.

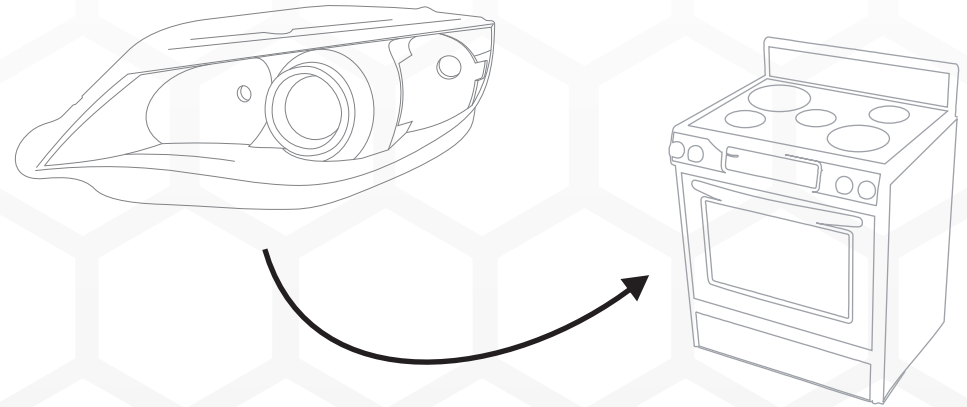

2

Using a flathead screwdriver, pry gently on the seam holding the two housing halves together to separate them.

NOTE: Gloves are recommended!

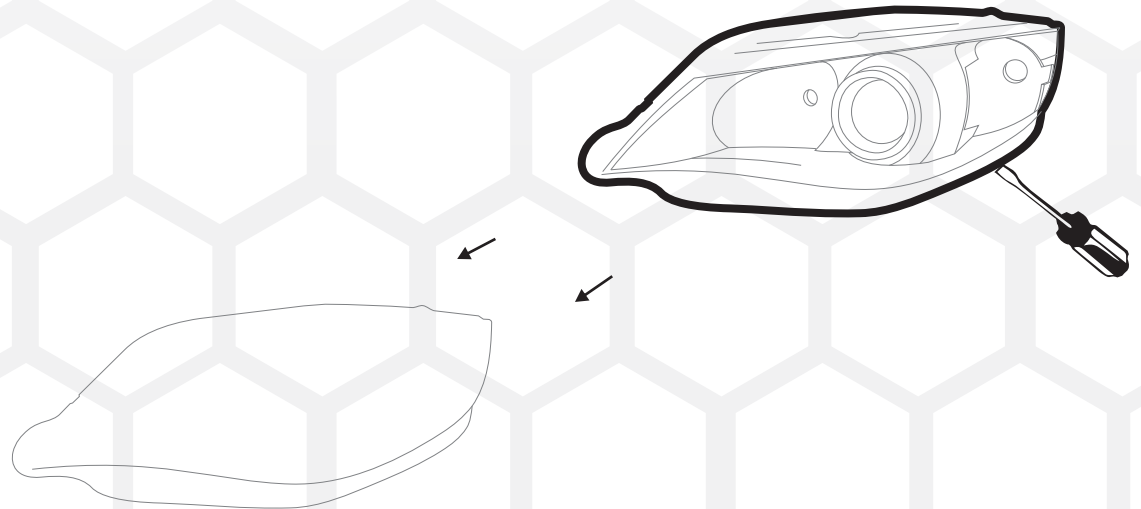

4

# HARDWARE ASSEMBLY

1

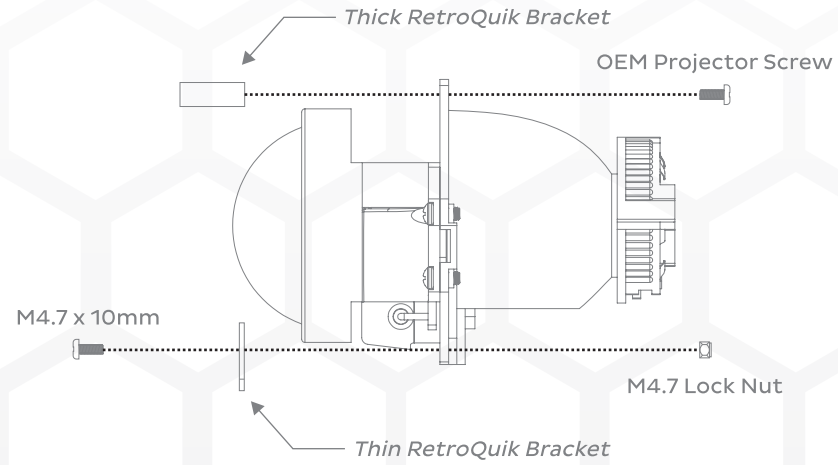

2

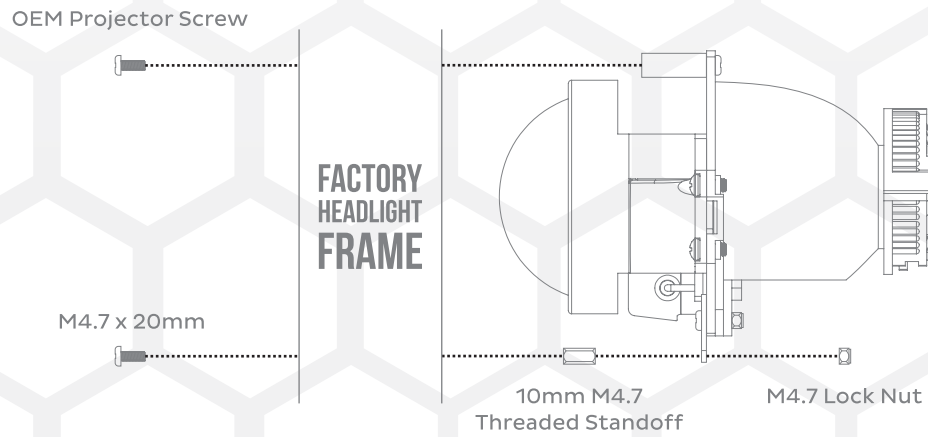

5

# RESEALING HEADLIGHTS

---

1

Because the stock sealant cannot be reused, remove all of the existing sealant from the channel and edge of the headlight lens.



2

Place bead of RetroRubber sealant in channel of headlight housing as shown. Fill the majority of the channel to ensure it sufficiently holds the front lens once re-installed.

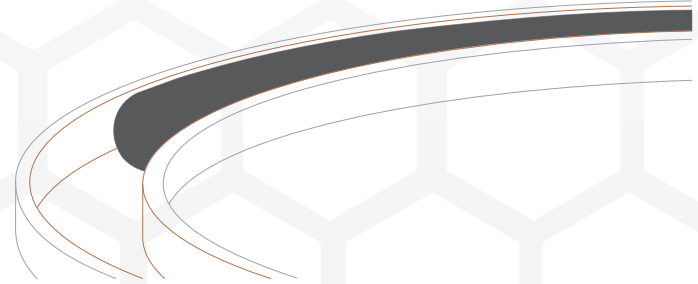

3

Use scissors to cut the RetroRubber once the entire circumference of the housing has been filled.

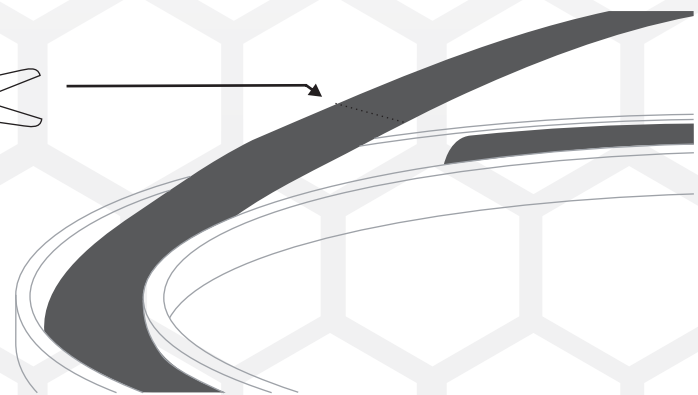
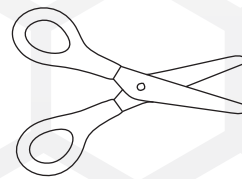

4

Re-fit headlight lens back over channel in headlight housing and press gently.



5

Place entire headlight in oven for seven (7) minutes at 270 Fahrenheit / 130 Celsius to soften the new sealant.

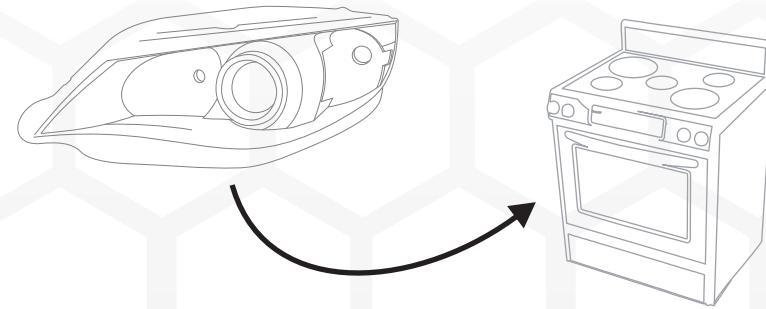

6

Using pliers, squeeze the channel back together snugly to ensure the RetroRubber creates a proper seal.

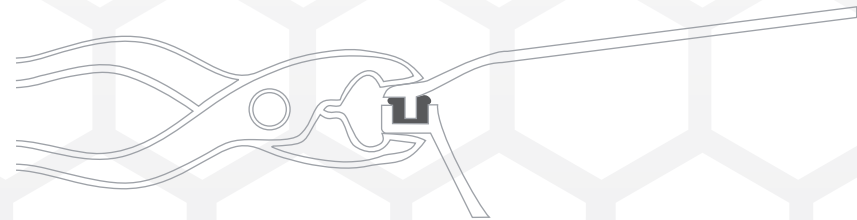

7

Allow thirty (30) minutes for headlight to sufficiently cool down prior to re-installation on car.

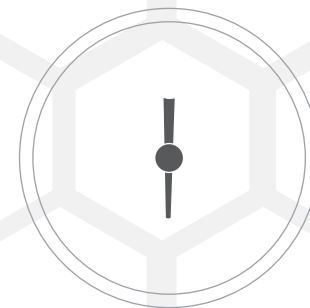

00:30:00

# HARNESS INSTALLATION

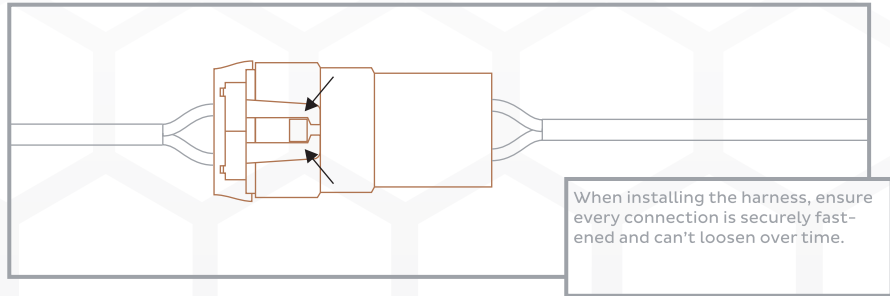

# SOLENOID WIRING

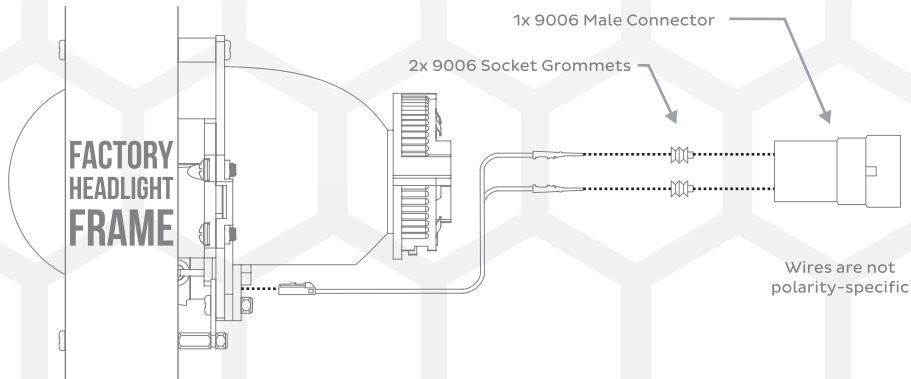

# BULB INSTALLATION



Do not ignite until fully connected



Waterproof

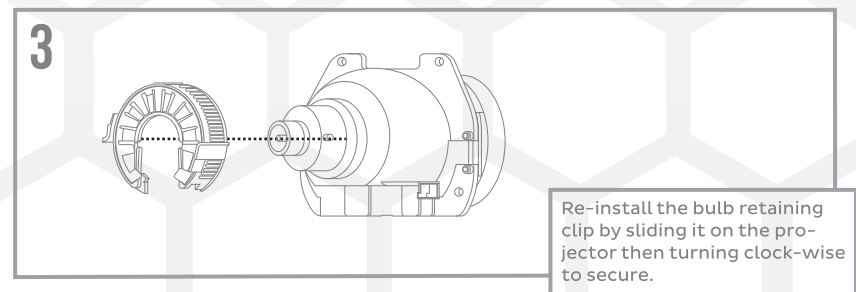
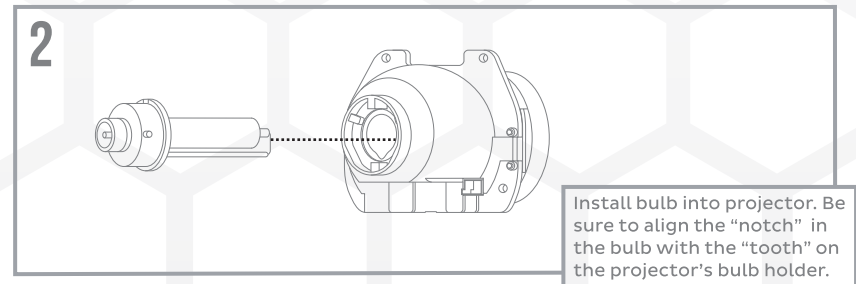
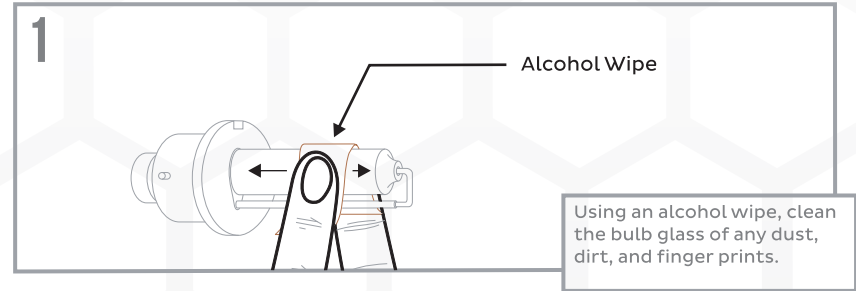



# BALLAST INSTALLATION



Ballasts are only waterproof when properly installed



Do not ignite until fully connected

1

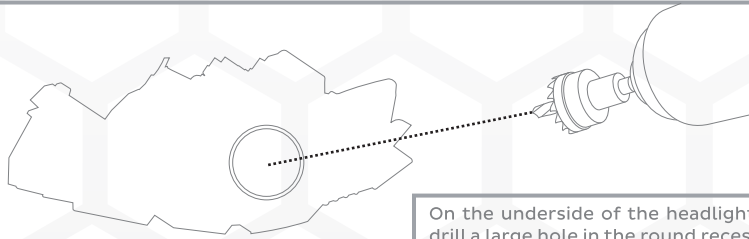

On the underside of the headlight, drill a large hole in the round recess where the ballast will mount to allow the igniter to pass through.

2

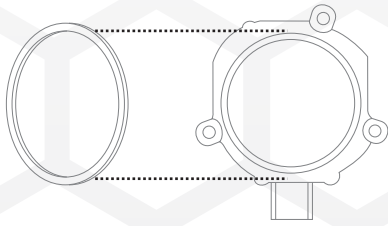

Fit the rubber O-Ring around the flange on the ballast.

3

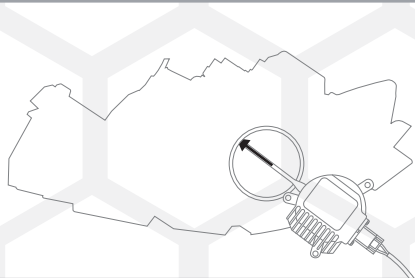

Route the igniter into the new hole of the housing.

3

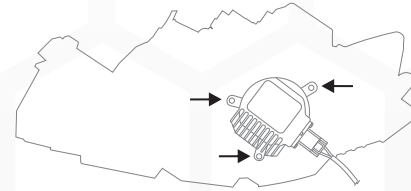

Using three screws (not included), securely fasten the ballast to the housing and tighten snugly

4

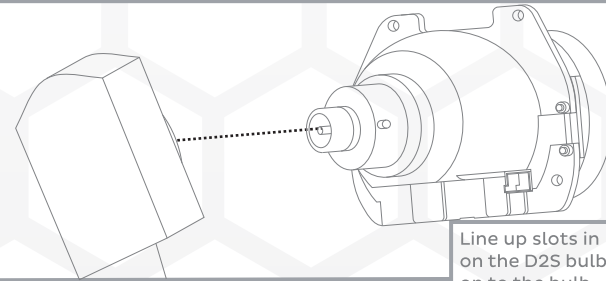

Line up slots in igniter with the tabs on the D2S bulb and slide the igniter on to the bulb.

5

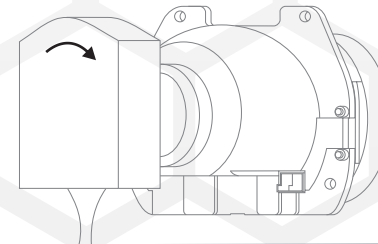

With the igniter pressed fully on to the bulb, turn the igniter clockwise and lock the igniter on to the bulb. You will feel a "click" upon doing this.

-END-