

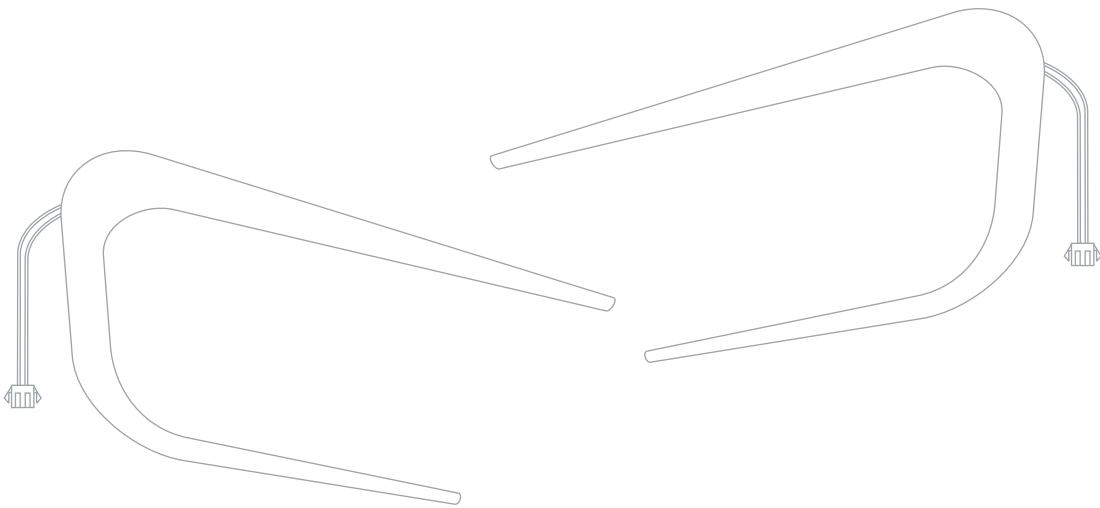

THE AUTOMOTIVE LIGHTING BENCHMARK

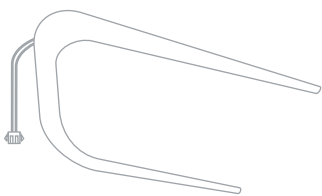

INSTALLATION GUIDE
2015+ WRX C-CLAMPS



1x

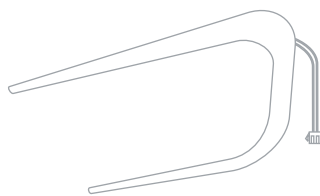

1x



2x



WARNING: By reading this document, I agree it is only to be used as an educational guide. Morimoto Lighting makes no guarantee on any finished results, nor are they to be held responsible for any damage, misuse, or personal injuries. Use at your own risk. If you are unable to clearly understand and adapt the information below to your own application, professional installation is recommended.

C-CLAMP INSTALLATION

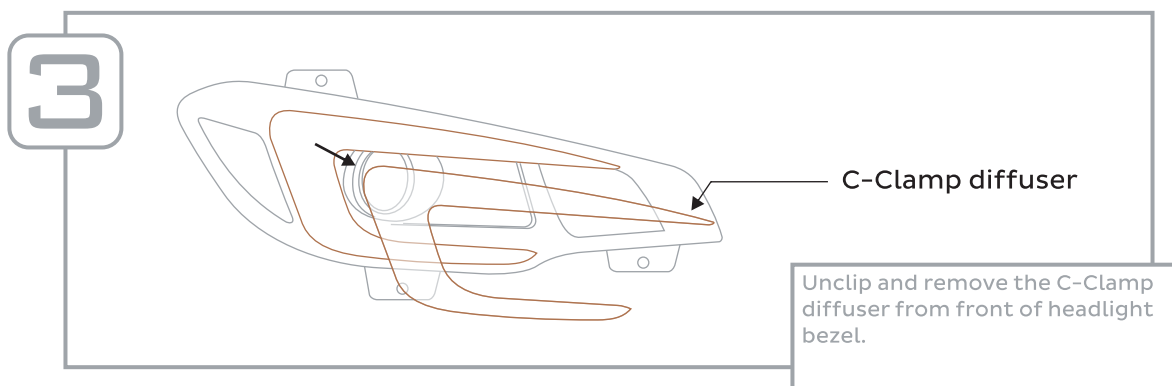
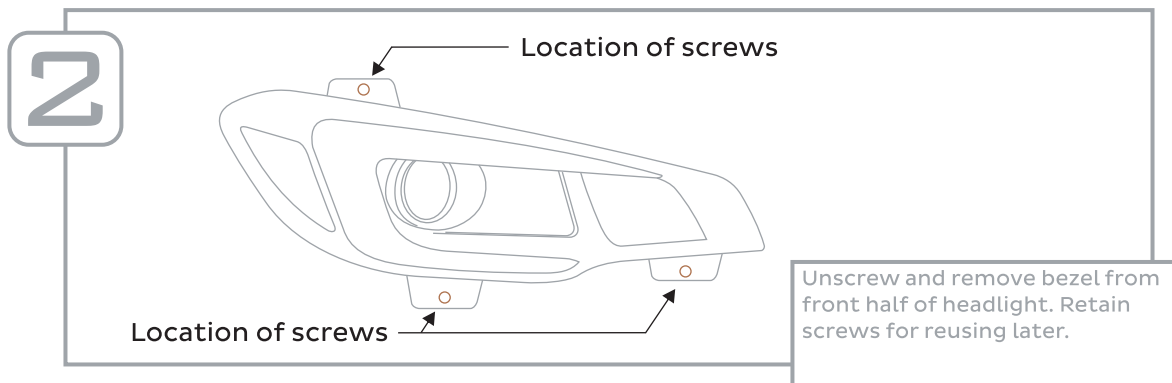
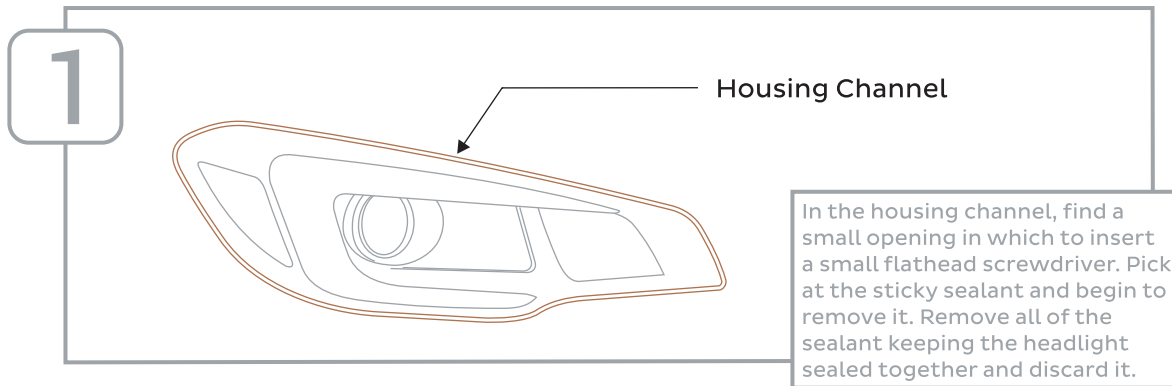

4

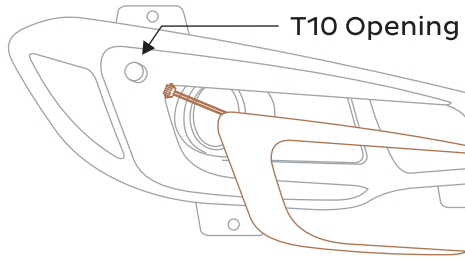

Connector first, insert the wiring for the C-Clamp through the T10 opening in the bezel and seat the C-Clamp into the bezel reflector area under the diffuser that was removed.

5

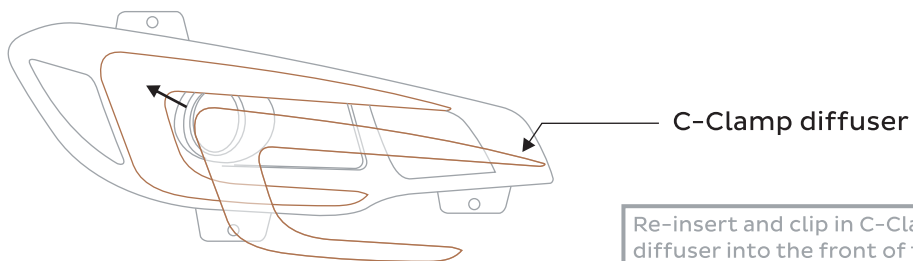

Re-insert and clip in C-Clamp diffuser into the front of the headlight bezel. The XSB light is held in with the diffuser only.



NOTE: Wipe off any finger prints and dust with a clean and soft microfiber towel prior to continuing.

6

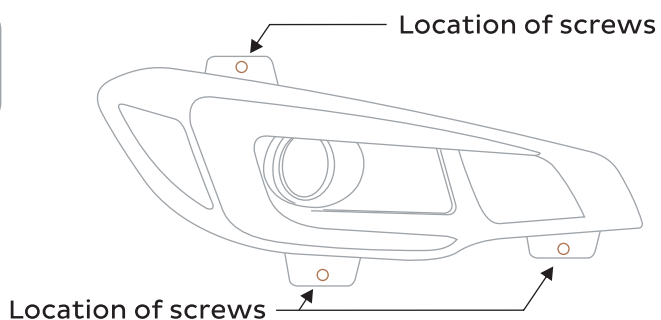

Insert bezel and re-insert screws into front half of headlight.



NOTE: Morimoto RetroRubber butyl sealant is the recommended sealant for re-sealing the stock housings. Other waterproof sealants can be used if preferred.

WIRING INSTALLATION

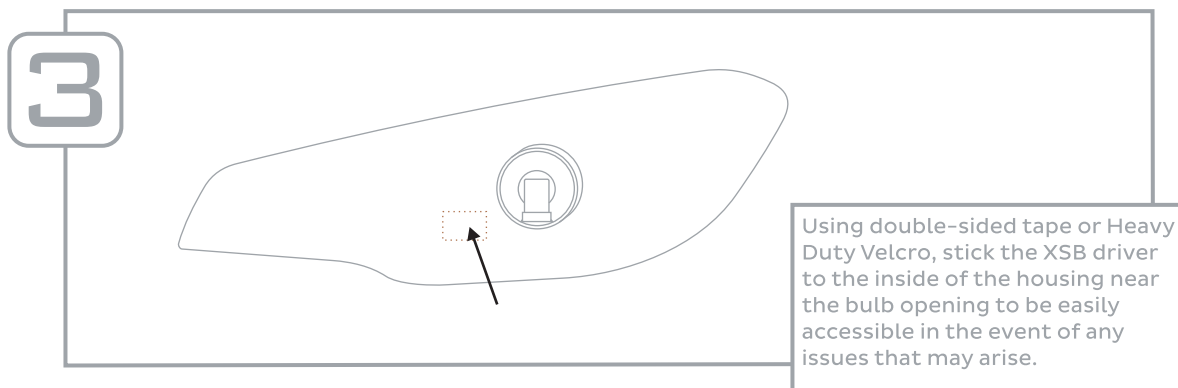
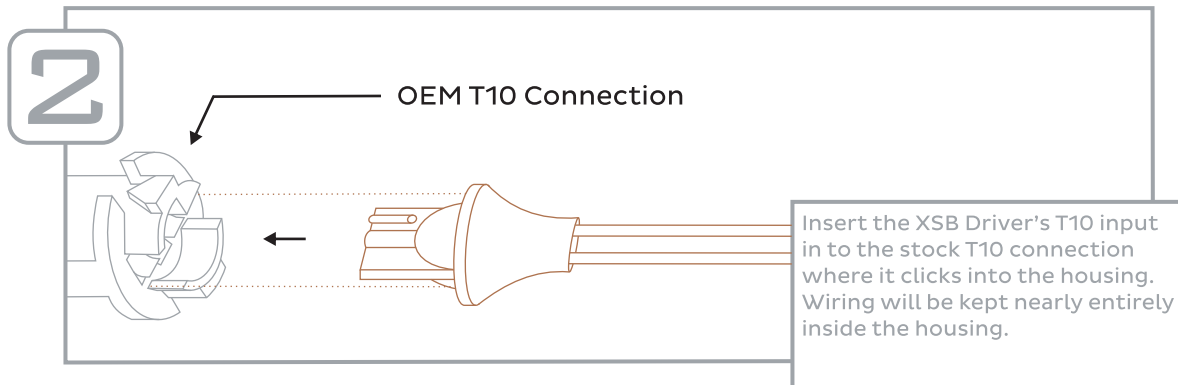
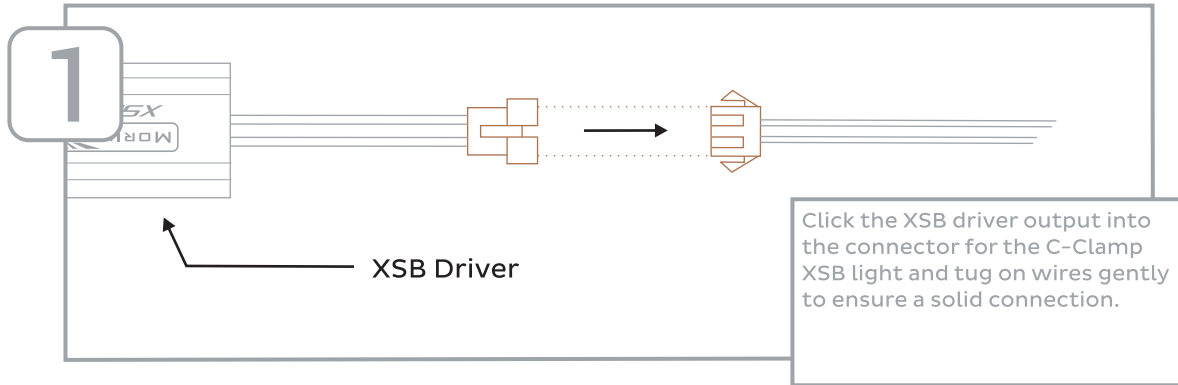

4

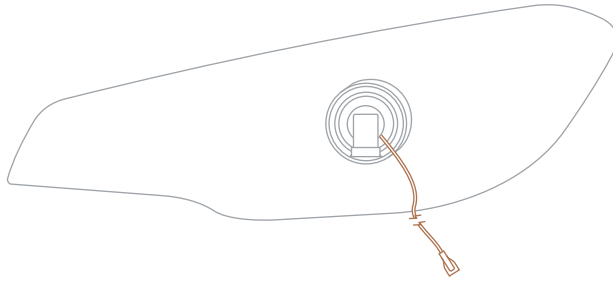

Route the yellow wire of the XSB driver up and out the grommet next to the H11 bulb.

5

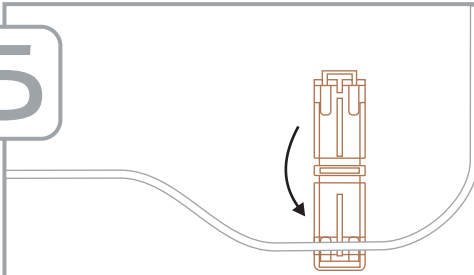

On the blue wire for the OEM turn signal bulb, install the provided crimp-on blue T-Tap.

6

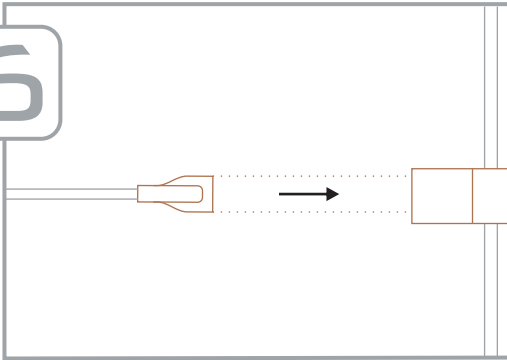

Insert the male spade terminal on the yellow wire of the XSB driver to the installed T-Tap to provide the turn signal of the XSB C-Clamp lights.

-END-